

User Manual for Oil Buster (OS56)

Technical Features (Band width 100 mm)

Power Supply:	230 VAC · 50 Hz · 7VA/24VAC
Capacity:	Max. 21 litres/oil pr. hour
Max temp.*:	90°C / 194°F (bath temperature)
Dimensions & weight:	210 x 220 x 125 mm · 3,0 kg.
Band lengths (mm.):	400 – 2000 mm (100 mm interval). Special requests for bands can of course be made.
pH range:	0-14
*Max temperature in pH neutral fluids. In strong acids/alkalis keep below 80°C/176°F	



Thank you for purchasing this oil skimmer. Oil Buster is a quality product made in electro polished stainless steel.

Oil Buster is a compact oil skimmer with an very high capacity which makes it ideal for large industrial baths and washing machines. Its unique design and axle tightening allows the skimmer to work in the most difficult places with high temperatures and strong acids or alkalis.

Unscrew the 3 screws which fastens the skimmer house the the motorhouse. Now pull off the skimmer house. Dismount the roll holder (1) and mount the band. After the band has been fitted, mount the roll holder (1) again. Now put the heave weight roll on the bottom of the band to stretch it out. Before setting back on the skimmer house, make sure that the band passes through the scrapes as I should, by plugging in the power supply for a short while. It is very important that this is done exactly according to this instruction, in order to get full capacity from the skimmer (see picture on the middle right, to see how the band is fitted correctly)

Now fasten the skimmer at the desired place using the Ø5,0 mm holes in the front and the back

When using the skimmer in high or low pH and or high temperatures it is very important to keep the motor house away from the steams. Hot or corrosive steams can break the engine, so it should be fitted in a way so these steams are lead away from the engine house (see the picture on the bottom right). The area marked with a red line, is the area which should be kept away from the steams, by eg. Fitting a blocking plate, or carving the hold to this part of the skimmer is not exposed to the steams. The area marked with a blue line can be exposed to the steams.

Now the skimmer is ready for use and the oil collection process can begin once you plug in the power. Connect to drainage to a collection container with a soft piece of hose (Ø 34mm / 13/8").

The oil skimmer is constructed for running continuously but using it in intervals when oil should be removed will save both mechanics and bands.

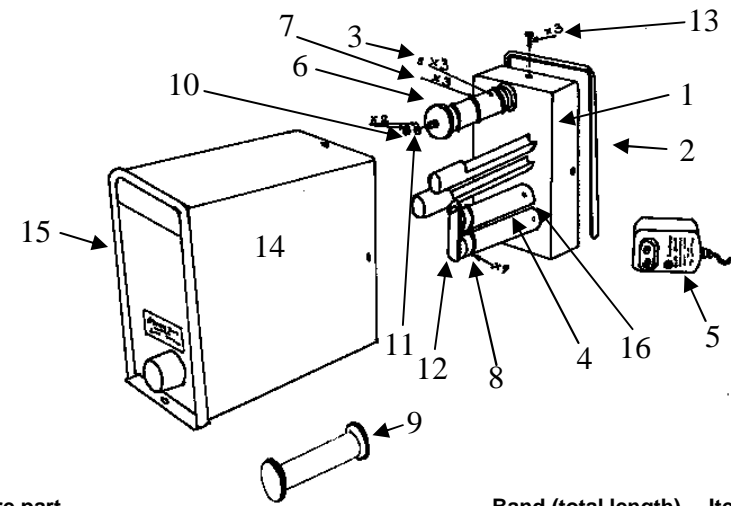
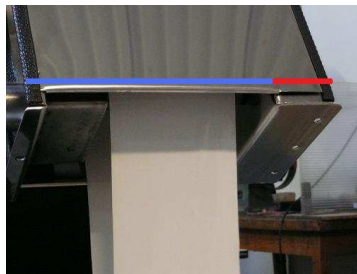

Spare part

		Band (total length)	Item no.
1) Motor house complete	5601	600 mm	100M 600
2) Buffer Back	5602	700 mm	100M 700
3) Lock screw	5603	800 mm	100M 800
4) 2 x Pulling roll *	5604	900 mm	100M 900
5) Plug-in adaptor	5605	1000 mm	100M 1000
6) Top Roll	5606	1100 mm	100M 1100
7) 3 x Rubber Rings Top	5607	1200 mm	100M 1200
8) 2 x 9 Rubber rings for pulling roll	5608	1300 mm	100M 1300
9) Heavy bottom roll	5609	1400 mm	100M 1400
10) Nut	5610	1500 mm	100M 1500
11) Disk	5611	1600 mm	100M 1600
12) Roll holder	5612	1700 mm	100M 1700
13) 3xScrews for skimmer house	5613	1800 mm	100M 1800
14) Complete Skimmerhouse	5614	1900 mm	100M 1900
15) Buffer Front	5615	2000 mm	100M 2000
16) 2 x Axle tightening	5616		

* Can only be replaced at the factory.

For other band length your distributor or the

Declaration of conformity / CE Declaration.

We, **SSR-TRADE**, Sundparken 7, DK-3600 Frederikssund, declare under our sole responsibility that this products:

Oil Skimmer Oil Buster (OS56)

to which this declaration relates is in conformity with the following standards:
EN 292-1:91, EN 292-2:91 & EN 60742:88
 following the provisions of **89/392/EEC & 73/23/EEC** directives.

This oil skimmer is CE certified

Warning!

Never use the Oil Skimmer in explosive environments