

## Instruction for refractometer for emulsions

### Maintenance and general information

When this refractometer is calibrated it should be done in same temperature as the temperature where the emulsion sample is taken.

After use you should never wash the refractometer, since this can cause water to enter the instrument. Use a piece of soft cotton (like the one which is delivered along with the refractometer) to wipe the prism and cover plate clean.

You should storage the refractometer in a dry and safe place. Avoid dropping the instrument. We advise you to keep the refractometer in the box in which it is delivered. Do not keep the refractometer in corrosive environments.

The calibration fluid should be kept in its bottle. Avoid getting the fluid in contact with eyes or skin.

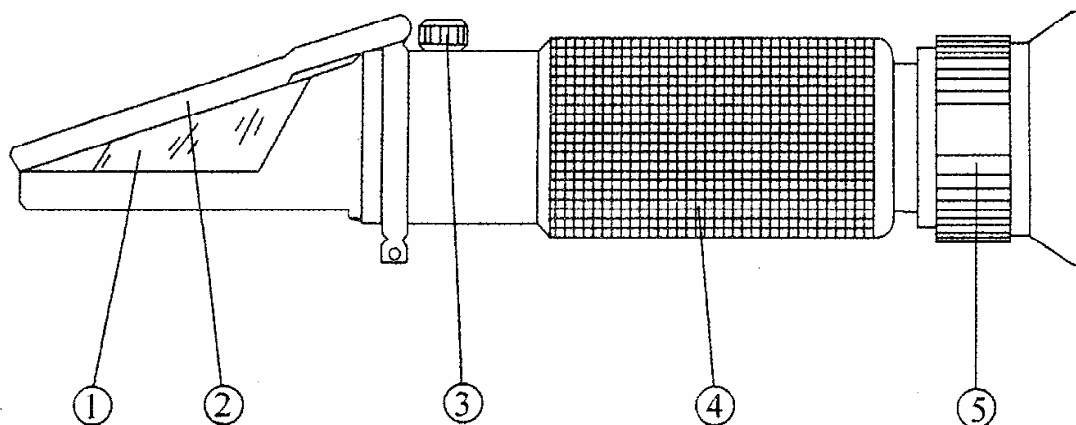

1. Prism - 2. Cover plate - 3. Calibration screw - 4. Mirror tube - 5. Diopter

### Instruction:

#### **Before use**

Point the refractometer towards a source of light and adjust the diopter (5) until you clearly see the scale.

#### **Calibration**

Open the cover plate (2). Ad a few drops of calibration fluid to the prism (1). Close the coverplate and make sure the fluid completely covers the prism. Adjust the calibration screw (screwdriver is found in the box) until the border between light and blue is exactly on the line of calibration.

#### **In use**

Open the cover plate. Wipe the prism with a clean piece of soft cotton or other soft textile (one is delivered along with the refractometer) Add a few drops of the emulsion liquid to the prism and close the cover plate. Ensure that the fluid completely covers the prism. Point the refractometer towards a source of light, and you will instantly be able to read the value. The value is shown at the border between light and blue.

#### **After use**

Wipe the prism and cover plate with a clean piece of soft cotton or other soft textile. Never flush your refractometer in water; this will cause water to enter the instrument.

#### *Accessories:*

- Calibration fluid
- Cotton for cleaning
- Pipette
- Screwdriver